



EXCELERATOR 2.1

***Media Excelerator 1.1 for Windows Media
Administration Guide***

Legal Notices

Volera, Inc. makes no representations or warranties with respect to the contents or use of this documentation, and specifically disclaims any express or implied warranties of merchantability or fitness for any particular purpose. Further, Volera, Inc. reserves the right to revise this publication and to make changes to its content, at any time, without obligation to notify any person or entity of such revisions or changes.

Further, Volera, Inc. makes no representations or warranties with respect to any software, and specifically disclaims any express or implied warranties of merchantability or fitness for any particular purpose. Further, Volera, Inc. reserves the right to make changes to any and all parts of Volera software, at any time, without any obligation to notify any person or entity of such changes.

This product may require export authorization from the U.S. Department of Commerce prior to exporting from the U.S. or Canada.

Copyright © 1997-2001 Volera, Inc. All rights reserved. No part of this publication may be reproduced, photocopied, stored on a retrieval system, or transmitted without the express written consent of the publisher.

U.S. Patent Nos. 5,870,739; 5,873,079; 5,884,304. Patents pending.

Volera, Inc.
2211 North First Street
San Jose, CA 95131-2021
U.S.A.

www.volera.com

Volera Media Exceleator 1.1 for Windows Media Administration Guide
June 2001

Online Documentation: To access the online documentation for this and other Volera products, and to get updates, see www.volera.com.

Volera Trademarks

Volera is a registered trademark of Volera, Inc. in the United States and other countries.

Third-Party Trademarks

All third-party trademarks (indicated by asterisks [*]) are the property of their respective owners.

Contents

- About This Guide** **7**
- 1 Overview of Windows Media Player Protocols** **9**
- 2 Using Streaming with Exceleator 2.1 Features** **13**
 - Caching Streaming Content 13
 - Support for Live Streams. 14
 - How Exceleator Manages Cache Freshness for Streaming Objects 14
 - Downloading Streaming Objects. 15
 - Pinning Streaming Objects. 15
 - Authenticating Streaming Services. 15
 - Purging Streaming Objects. 16
 - Logging. 16
 - Manually Downloading and Deleting Log Files 16
 - Downloading Log Files 19
 - Extended Log Field Headers 19
- 3 Installing Media Exceleator for Microsoft Windows Media** **23**
 - Purchasing a Media Exceleator License 23
 - Installing the Activation License from Floppy Disk 24
 - Installing the Activation License Using FTP 24
 - Installing Media Exceleator Patches 25
 - Downloading the Latest Patches 25
 - Updating the Appliance's Backup System Image 26
 - Backing Up Your License 26
- 4 Accelerating Streams to Individual Media Players** **27**
 - Overview of Forward Streaming Proxy. 27
 - Key Functionality 27
 - How Forward Streaming Proxy Works 28
 - Benefits of Forward Streaming Proxy 28
 - Forward Streaming Proxy Setup 29
- 5 Accelerating Streams to all Players on a Network Without Configuring Them** **35**
 - Overview of Transparent Streaming Proxy. 35
 - Transparent/L4 Streaming Proxy. 36
 - Key Functionality 36

- How Transparent Streaming Proxy Works with an L4 Switch 36
- Benefits of Transparent Streaming Proxy with an L4 Switch 36
- Setting Up Transparent Streaming Proxy with an L4 Switch 37
- Transparent/WCCP Streaming Proxy 40
 - Key Functionality. 40
 - How Transparent Streaming Proxy Works with a WCCP-Capable Router 40
 - Benefits of Transparent Streaming Proxy with a WCCP-Capable Router 41
 - Setting Up Transparent Streaming Proxy with a WCCP-Capable Router 41
- Transparent/Default Gateway Setup 46
 - Key Functionality. 46
 - How Transparent Streaming Proxy Works as a Default Gateway 46
 - Benefits of Transparent Streaming Proxy as a Default Gateway 47
 - Setting Up a Transparent Streaming Proxy as the Default Gateway 47
- Transparent/Inline Router Setup 50
 - Key Functionality. 50
 - How Transparent Streaming Proxy Works as an Inline Router 50
 - Benefits of Transparent Streaming Proxy as an Inline Router. 51
 - Setting Up a Transparent Streaming Proxy as an Inline Router 51
- 6 Accelerating Streaming Media Servers 55**
 - Overview of Streaming Media Server Acceleration 55
 - How Origin Streaming Server Acceleration Works 56
 - Benefits of Origin Streaming Server Acceleration 57
 - Streaming Server Accelerator Setup 58
- 7 Streaming Content Through Firewalls 63**
 - Setting Up Your Appliance to Work with NATs and Firewalls 64
 - Placing the Appliance Outside the Firewall 64
 - Placing the Appliance Inside the Firewall 65
 - Using the Appliance as a Component to the Firewall 65
- Index 67**

6 Volera Media Exceclerator 1.1 for Windows Media Administration Guide

About This Guide

Use this guide to install and configure the Volera™ Media Excelerator (v1.1) for Microsoft Windows Media. Windows Media is provided by Microsoft Media Services (MMS).

For information about Volera™ Excelerator 2.1, see the Volera Excelerator 2.1 Administration Guide.

NOTE: The term *appliance* as used in this guide refers to appliances from Volera partners and Volera-approved hardware, including server-class machines.

8 Volera Media Excelerator 1.1 for Windows Media Administration Guide

1

Overview of Windows Media Player Protocols

This chapter introduces the general features of Volera™ Media Excelerator for Windows Media.

If you want more general information regarding streaming media, see Streaming Media Overview in the Volera Excelerator 2.1 Administration Guide.

The following table summarizes the protocols supported by the Windows* Media Player* and the advantages and disadvantages associated with each protocol:

Table 1 Windows Media Player Protocol Support

Protocol Name	Protocol Details	Advantages	Disadvantages	Exceclerator Streaming Support
MMS in HTTP	<p>MMS in HTTP in TCP: Both control and media data.</p> <p>Transparent and reverse services use 80 as their standard port.</p> <p>Forward services most commonly use port 8080.</p>	<ul style="list-style-type: none"> ◆ Uses the Web's most standard protocol. ◆ Setup is easy. ◆ Provides guaranteed delivery of media data. ◆ Supports realtime delivery of media data. ◆ Lets players fast-forward, pause, etc. ◆ Passes through firewalls with other Web data. 	<ul style="list-style-type: none"> ◆ Slight protocol overhead for guaranteed delivery. 	Media Exceclerator (v1.0 and later) for Microsoft Windows Media
MMS in TCP	<p>MMS in TCP: Both control and media data.</p> <p>Transparent, reverse, and forward services use 1755 as their standard port.</p>	<ul style="list-style-type: none"> ◆ Guaranteed delivery of media data. ◆ Supports realtime delivery of media data. ◆ Lets players fast forward, pause, etc. 	<ul style="list-style-type: none"> ◆ Might be blocked by firewall. ◆ Slight protocol overhead for guaranteed delivery. 	Media Exceclerator (v1.1) for Microsoft Windows Media

10 Volera Media Exceclerator 1.1 for Windows Media Administration Guide

Protocol Name	Protocol Details	Advantages	Disadvantages	Exceleator Streaming Support
MMS in UDP	<p>MMS in TCP: Control data.</p> <p>MMS in UDP: Media data.</p> <p>Transparent, reverse, and forward services use 1755 as their standard port for TCP (control data). UDP (media data) uses a dynamically allocated port number.</p>	<ul style="list-style-type: none"> ♦ UDP provides the most efficient network throughput to the players. ♦ Supports realtime delivery of media data. ♦ Lets players fast-forward, pause, etc. 	<ul style="list-style-type: none"> ♦ May be blocked by firewall. ♦ UDP packet delivery is unreliable. When used to fill the cache, the stream that is cached may be a lower quality. 	<p>Media Exceleator (v1.1) for Microsoft Windows Media</p> <p>NOTE: UDP requests are filled using TCP unless the Allow UDP for Filling option is checked when a media cache service is created.</p>

12 Volera Media Excelerator 1.1 for Windows Media Administration Guide

2

Using Streaming with Excelerator 2.1 Features

This chapter contains information that is specific to Microsoft Windows Media*.

The Volera Excelerator 2.1 Administration Guide contains information regarding other Excelerator™ features, including support for QuickTime* media.

Instructions for creating Microsoft Windows Media caching services begin in Chapter 4, “Accelerating Streams to Individual Media Players,” on page 27.

Caching Streaming Content

MMS streams are cached based on the contents of the stream, rather than the URL. If different users access the same stream from multiple URLs, only one copy is kept. This applies whether the stream is filled via HTTP, TCP, or UDP, and regardless of which service type (forward, transparent, or accelerator) is used.

Users are able to access a copy of the stream using any of the three protocols. For variable bandwidths streams, each bandwidth is stored as a separate object. This ensures that only the bandwidths currently being used are cached.

One way to ensure complete caching of streams is to preload streams into cache that you know users will be requesting later. This can be done via the site download feature of Excelerator 2.1. You can configure Media Excelerator to load the streams during off hours when bandwidth demands on your Internet connection are low.

Support for Live Streams

You can provide multiple-player access to live MMS and RTSP streams by creating an Excelerator proxy service (forward, transparent, or reverse) between the origin streaming server and the requesting players. Excelerator 2.1 automatically "splits" the live stream. In other words, it retrieves a single stream from the origin streaming server and then serves that stream to many requesting players.

While most origin streaming servers can handle only a relatively small number of simultaneous player connections, Excelerator 2.1 has been tested at over 26,000 connections for MMS live streams. Excelerator 2.1 lets you increase the availability of live stream broadcasts by orders of magnitude without installing additional streaming servers. At the same time, Excelerator frees up the origin streaming server's connection bandwidth for handling other content requests.

Excelerator's feature of splitting live streams lets you service thousands of player requests with very little impact on your origin streaming server and network.

How Excelerator Manages Cache Freshness for Streaming Objects

The cache freshness revalidation settings for HTTP (on the Cache > Tuning tab) and RTSP (on the Streaming > Streaming Management Configuration tab) do not apply to Windows Media objects.

Instead of referring to header values or using Excelerator freshness settings for streamed objects, Media Excelerator revalidates Windows Media objects with every request.

Windows Media objects do not expire in cache. Instead, the system removes the objects when:

- ◆ It needs memory or disk resources for newly requested objects.
- ◆ Objects are purged as described in "Purging Streaming Objects" on page 16.
- ◆ Storage settings are hit.

Downloading Streaming Objects

You can automatically download streaming media objects using the Cache > Download > Insert dialog box. The syntax for downloading a specific media file, for example, is `mms://volera.com/media/somemovie.asf`. You must have a forward HTTP Client accelerator and a Forward MMS service enabled prior to downloading.

To download streams using an .asx file (MMS playlist file), set the Levels to Download from web site to 2 or greater in the Cache > Download > Insert dialog. For example, `http://volera.com/media/somemovie.asx`. Because .asx files usually reference other .asx files, you should set the levels to at least 3 if you don't know the exact number of required levels.

If links to other items such as graphics are contained in the .asx files, they will be downloaded as well.

To control the amount of bandwidth used for downloading, you may also need to modify the "Maximum number of concurrent requests" and "Maximum amount of data to download" parameters.

When a stream is downloaded, the Excelerator downloads each possible bitrate combination of the stream. Downloading streaming objects takes at least as long as it does for the player to play the stream. If the duration of a movie is two hours, for example, then downloading the movie stream will take at least two hours. It may take longer if the download is performed across low bandwidth connections.

Pinning Streaming Objects

Object Pinning in the Volera Excelerator 2.1 Administration Guide contains explanations and examples of how you can ensure certain objects are retained in cache as long as possible.

Excelerator treats streaming objects that match pin list entries the same as it treats any other matching objects. In order to pin and download MMS objects, use a URL that begins with the MMS: scheme.

Authenticating Streaming Services

You can use streaming services with authentication enabled either at the streaming server or at the excelerator appliance. When authentication is

enabled at the streaming server, the user identity is made known to the streaming server but not to the excelerator appliance. The excelerator appliance allows this to work over any of the MMS protocols.

When authentication is enabled at the excelerator appliance, the user identity is made known to the excelerator appliance but not to the streaming server. The excelerator appliance only supports basic authentication over the HTTP-MMS protocol. Care should be taken when utilizing this feature because it can conflict with streaming server authentication. Basic authentication is not set on the streaming service but on the associated HTTP service. For more information on basic authentication, see *Authentication Services in the Volera Excelerator 2.1 Administration Guide*.

Purging Streaming Objects

The browser-based management tool lets you purge objects from cache using the System > Actions > Purge Cache dialog. You can purge all Windows Media objects from the cache by typing "mms://*". You can also purge specific objects if you know the name of the URL.

For more information on caching streaming content, see *Preparing to Cache Streaming Media Data in the Volera Excelerator 2.1 Administration Guide*.

Logging

Logging appliance caching activity can be useful for a number of reasons, such as billing for services rendered. Excelerator lets you specify how often a new log file will be started (rolled over), how long log files will be retained, and what the format of the log files will be. For more information, see *Logging in Volera Excelerator 2.1 Administration Guide*.

Manually Downloading and Deleting Log Files

Whenever possible, we recommend you use the FTP Log Push feature to download and delete log files. See *Using FTP Push to Automatically Download and Delete Log Files in Volera Excelerator 2.1 Administration Guide*

If you need to manage your log files manually, you should establish a regular schedule and ensure that all those responsible for downloading and deleting log files know the following:

- ◆ When log files are to be downloaded and deleted
- ◆ How to determine the name of each log file to be downloaded and deleted
- ◆ Where to save the log files

You will want to develop specific procedures for your situation. The following sections contain general ideas for accomplishing these tasks.

Getting Log Filenames

Before you can download or delete a log file, you must know its exact name.

Appliance log filenames can be listed in the browser-based management tool in Monitoring > Cache Logs. They can also be listed from the command line or through a Telnet session using the **GET** command.

The appliance automatically generates log filenames as follows:

- ◆ Six numbers representing the year, month, and day the file was created
- ◆ A dash separating the date from a letter identifier
- ◆ Letter identifiers running from A through ZZ

NOTE: The dash is not included after the letters double (AA-ZZ).

This naming convention accommodates up to 702 log files per day. If the rollover options are set so that all the possible filenames are used in one day, the log file with the ZZ letter identifier is not closed until the start of the next day (unless the logging disk becomes full).

To list log files using FTP, you must know the path to the files. Use the following table to determine the paths to MMS log files.

File	Location
MMS log files in extended format	LOG:ETC/PROXY/DATA/LOGS/SMC/EXTENDED/ <i>name</i> The variable <i>name</i> is the name of the streaming service.

Using the Browser-Based Tool to Get Filenames

You can most easily view log filenames in the browser-based management tool. To do so, click Monitoring > Cache Logs. Select a log format, then select a service.

Using FTP to Get Filenames

The Mini FTP Server in version 1.3 and later supports the CWD command for changing to the target log directories. All appliance versions let you use the LS command in connection with full paths to list log files.

For example, the following command lists transparent and forward proxy log files in extended format:

```
ls log:etc/proxy/data/logs/smc/extended/
```

For a complete list of log file directory paths, see “Getting Log Filenames” on page 17.

Using the Command Line or Telnet to Get Filenames

You can see a list of log filenames from the command line, but you cannot download files from the command line.

The following table presents some command line/Telnet examples.

If You Want To	Then Enter
See a list of available forward/transparent log files in common format	<code>get comlog forward</code>
See a list of available Web server accelerator log files in common format	<code>get comlog reverse:name</code> (The variable <i>name</i> is the name of the Web server accelerator.)
See a list of available filtering log files in appliance-filtering common format	<code>get comlog filter</code>
See a list of available forward/transparent log files in extended format	<code>get extlog forward</code>
See a list of available Web server accelerator log files in extended format	<code>get extlog reverse:name</code> (The variable <i>name</i> is the name of the Web server accelerator.)

Downloading Log Files

Using the Browser-Based Management Tool to Download Log Files

You can download the files in the browser-based management tool as you view them. After you click Download, the browser asks what you want to do with the file. Save it to your designated log file storage location.

Using FTP to Download Log Files

You can use FTP and the **GET** command to retrieve log files from the storage location. To retrieve a file from storage, you must first obtain the log filename using one of the options explained in "Getting Log Filenames" on page 17.

After you have the log filename, you can transfer the file to your workstation from the storage location. For example, to download a forward proxy common format log file, start an FTP session with the appliance and enter:

```
get log:/etc/proxy/data/logs/forward/common/filename.log
```

The *filename* variable is the name of the log file you are downloading.

NOTE: You can also use the `mget` command, but be aware that this command also downloads active log files that are not complete.

NOTE: The appliance doesn't currently support the FTP server `put` command.

Deleting Downloaded Log Files

After the log files have been downloaded and saved to another location, delete the files using one of the following options:

- ◆ The Delete button in the browser-based management tool
- ◆ The **DEL** command in FTP

Extended Log Field Headers

The following information about field values in extended log files will help you interpret the content of the files:

- ◆ Fields within the file are delimited by the tab character.
- ◆ A field is of two types: string and non-string.
- ◆ String fields are enclosed in quotation marks (").

- ◆ If a string field contains a quotation mark ("), that character is repeated once for every occurrence to enable unambiguous file parsing.
- ◆ If a string field has no value, it is represented by two quotation marks ("").
- ◆ Non-string fields containing no value are represented by a hyphen (-).
- ◆ Field headers starting with **s-** are associated with the appliance.
- ◆ Field headers starting with **c-** are associated with the client/browser.
- ◆ Field headers starting with **sc** are associated with flow from the appliance to the client/browser.
- ◆ Field headers starting with **cs** are associated with flow from the client/browser to the appliance.
- ◆ Field headers starting with **rs** are associated with flow from the server to the appliance.

The information in the following table is supplementary to the W3C Extended Log Format Specification found on the Extended Log File Format (<http://www.w3.org/TR/WD-logfile>) Web site. You might find it useful for interpreting the content of extended log field headers.

Name	Description	Type	Selectable	Comments
date	GMT date in YYYY-MM-DD format	non-string	No	
time	GMT time in HH:MM:SS format	non-string	No	
c-ip	Client (browser) IP address	non-string	No	
s-ip	The appliance IP address	non-string	Yes	
cs-method	HTTP request method	non-string	Yes	
cs-uri	The URL used by the player to request content	non-string	Yes	The URL must not have spaces per the HTTP specification.
sc-status	For HTTP only	non-string	Yes	

20 Volera Media Exceleator 1.1 for Windows Media Administration Guide

Name	Description	Type	Selectable	Comments
sc-bytes	Bytes received from player	non-string	No	
cs-bytes	Bytes sent to player	non-string	No	
rs-bytes	Bytes received from origin	non-string	No	
x-fill-proxy-ip	IP address of upstream proxy used for filling requests	non-string	Yes	
x-origin-ip	IP address of streaming server used for filling requests	non-string	Yes	

22 Volera Media Exceleator 1.1 for Windows Media Administration Guide

3

Installing Media Excelerator for Microsoft Windows Media

This chapter covers the process of installing Media Excelerator. Prior to beginning the installation, you must purchase a license. To do this,

- 1 Browse to the Volera Website (<http://buy.volera.com>).
- 2 Locate the download area for Media Excelerator.
- 3 Complete the payment process.
- 4 When you are prompted to download the license file, do one of the following:
 - ♦ Save the license file to a blank, formatted floppy disk.Or
 - ♦ Save the file on a hard drive.

Excelerator product licenses have .LIC filename extensions.

IMPORTANT: If you use a floppy disk that was previously in an appliance's floppy disk drive, ensure that the disk does not contain an AUTOLOAD.NAS file.

An AUTOLOAD.NAS file causes the appliance's configuration settings to be automatically overwritten when the floppy disk containing the file is inserted in the appliance.

- 5 After purchasing a Media Excelerator license, continue to the Thank You page.
- 6 Note the Download URL for future reference.

You will use this URL to install Media Excelerator in "Installing Media Excelerator Patches" on page 25.

NOTE: Volera also sends you the Download URL in a confirmation e-mail.

- 7** Install the license on the appliance using one of the following methods:
 - ♦ If you have direct access to the appliance, you can use a floppy disk and the command line interface to install the activation license. See the instructions in “Installing the Activation License from Floppy Disk” on page 24.
 - ♦ If you do not have direct access to the appliance, you can install the license using FTP. See the instructions in “Installing the Activation License Using FTP” on page 24.

Installing the Activation License from Floppy Disk

To install the activation license, complete the following steps:

- 1** Insert the floppy disk containing the license file into the appliance’s floppy disk drive.
- 2** At the system prompt, enter
`importlicense floppy`
- 3** Remove the diskette and restart the appliance.
- 4** Continue with “Installing Media Exceleator Patches” on page 25.

Installing the Activation License Using FTP

If you have not used an FTP connection to manage your appliance, you should review the information in FTP Services in the Volera Exceleator 2.1 Administration Guide.

Complete the following steps:

- 1** Launch your FTP application and enter an appliance IP address that is enabled for FTP access.

For help with enabling FTP access, see Setting Up Appliance FTP Services in the Volera Exceleator 2.1 Administration Guide.
- 2** Log in to the appliance using the Config username.
- 3** If you have set a Config username password, enter it when prompted. Otherwise, press Enter.
- 4** FTP the license file from your workstation to the appliance. ETC/
PACKAGE directory.

IMPORTANT: When using MS-DOS to FTP files to the appliance, use the following syntax: put <source path>\filename.lic SYS:/ETC/PACKAGE/filename.lic

Example: put C:\licenses\MMS21.LIC /ETC/PACKAGE/MMS21.LIC

IMPORTANT: When using an FTP client you must set a password for the config user. Be sure to transfer the file as a binary file to the ETC\PACKAGE directory.

5 Continue with Installing Media Exceleator Patches.

Installing Media Exceleator Patches

Complete the steps in the following sections for each appliance on which you are installing Media Exceleator.

Downloading the Latest Patches

IMPORTANT: Volera provides URLs to the latest product patches with each license purchased. The URLs must be applied in the order listed in the Thank You page and in the confirmation e-mail.

You should always install all product patches *before* configuring and using an Exceleator product.

Complete the following steps:

- 1** In the browser-based tool, select System > Upgrade, and then select Enable Download.
- 2** In the Install from URL field, type the first Download URL received on the Thank You page and in the confirmation e-mail.
- 3** Double-check the URL to ensure you typed it correctly.
- 4** From the Download Time drop-down list, select the time you want the download to occur.
- 5** Select Enable Install.
- 6** From the Install Time drop-down list, select the time you want the upgrade installed.
- 7** Click Apply.

The upgrade process always restarts the appliance, temporarily disconnecting the browser-based tool.

- 8** After the appliance restarts, reconnect to the appliance using the browser-based management tool. Repeat this process for any other URLs received on the Thank You page and in the confirmation e-mail.
- 9** After all product patches have been applied, continue with Updating the Appliance's Backup System Image.

Updating the Appliance's Backup System Image

You should update the appliance's clone image as soon as possible after you complete an upgrade.

- 1** Reconnect to the appliance using the browser-based management tool.
- 2** Click System > Actions > Update Clone > Update Clone.

This prevents the system from being overwritten by an earlier version.

Backing Up Your License

After downloading the Media Exceleator license, you should save a backup copy.

Complete the following steps:

- 1** Insert a blank, formatted floppy disk in the appliance's diskette drive.
- 2** At the system prompt, enter the following command:

```
exportlicense floppy
```

- 3** Remove the diskette.

IMPORTANT: The exported license now has an .lcx extension and must be imported from floppy. If this .lcx file is put on the appliance using ftp, it will not be read as a valid license.

4

Accelerating Streams to Individual Media Players

This section presents a conceptual overview of Media Exceleator 1.1 for Windows Media* streaming forward proxy services.

Setup instructions are found in “Forward Streaming Proxy Setup” on page 29.

Key Functionality

You can configure Windows media players with the IP address of a streaming forward proxy service you have created on the appliance.

After they are properly configured, the players send streaming requests directly to an appliance IP address configured for streaming forward proxy services. The streaming forward proxy service obtains the media streams, caches them, and sends copies of the streams back to the players in the same way they would expect to receive the streams from origin streaming servers. Forward proxy configuration for the MMS protocol is only available on Windows Media Player versions 7 and above. The only choices for supporting earlier versions of the players with the MMS protocol is through the use of transparent or accelerator proxies.

How Forward Streaming Proxy Works

Figure 1

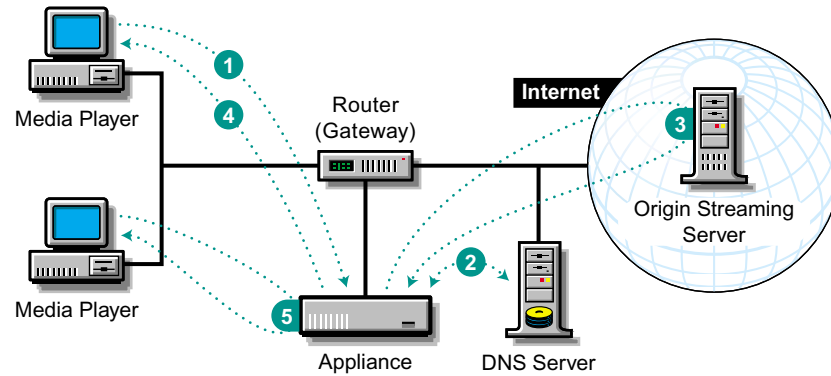

- 1 A player requests a stream from its forward proxy server (the appliance).
- 2 The forward proxy service obtains the numeric IP from DNS.
- 3 The service begins to fill the stream from the origin streaming server.
- 4 The service transmits the stream in real time to the player.
- 5 The streaming forward proxy service handles subsequent requests for the same stream from cache.

For information on the streaming protocol support used in streaming requests, see Table 1, “Windows Media Player Protocol Support,” on page 10.

Benefits of Forward Streaming Proxy

- ◆ Doesn’t require a special router configuration
- ◆ Provides an immediate improvement in player performance and server scalability
- ◆ Lets users decide whether to use the proxy service
- ◆ Reduces bandwidth costs

For tips and guidelines on setting up forward proxy services, see “Forward Streaming Proxy Setup” on page 29.

Forward Streaming Proxy Setup

Figure 2 and Figure 3 provide a visual map for the information in this section.

NOTE: The letters in Figure 2 and Figure 3 are referenced in the table that follows. The addresses shown are for illustration purposes only. You will need to substitute actual addresses for your network.

Figure 2

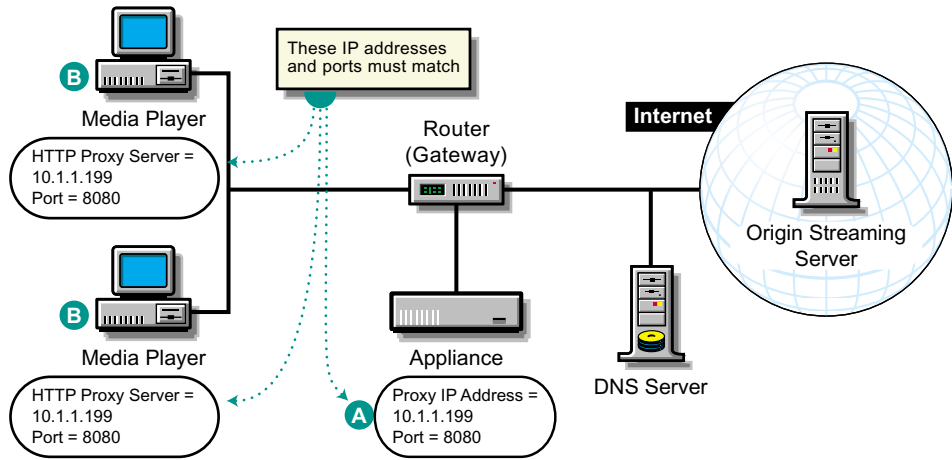
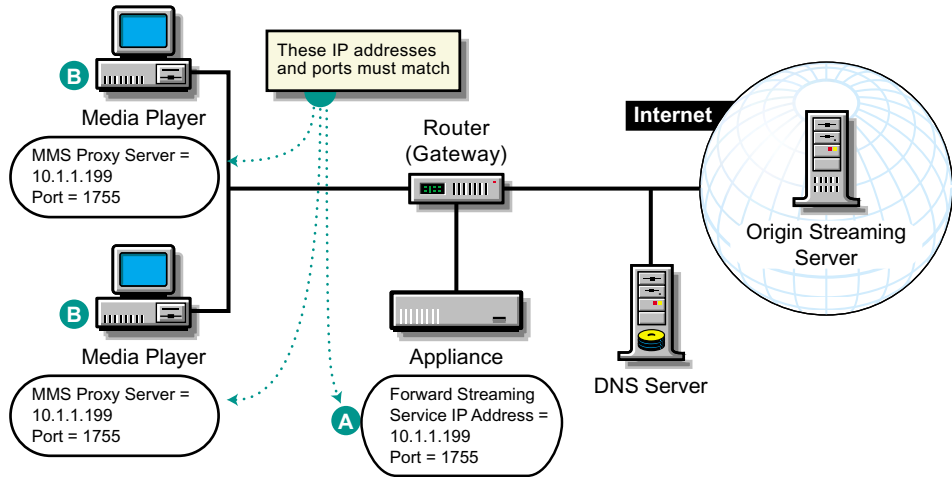

Figure 3



Set up forward proxy services as follows:

To	Do This	Notes
Understand Media Excelerator's features.	<ol style="list-style-type: none"> <li data-bbox="613 409 987 609">1. To ensure you achieve the results you expect, we recommend you read the information in Chapter 2, "Using Streaming with Excelerator 2.1 Features," on page 13. 	
Ensure your basic network configuration is complete.	<ol style="list-style-type: none"> <li data-bbox="613 640 987 756">1. See Basic Network Configuration Setup in the Volera Excelerator 2.1 Administration Guide. 	
Enable HTTP forward proxy services on the appliance.	<ol style="list-style-type: none"> <li data-bbox="613 783 987 871">1. In the browser-based tool, click Cache > Client Accelerator. <li data-bbox="613 882 987 970">2. Check Enable Client Acceleration (Forward Proxy). <li data-bbox="613 980 987 1050">3. Check the IP address for the forward proxy service. <li data-bbox="613 1060 987 1123">4. Set the Proxy Port to 8080 (the default). <li data-bbox="613 1134 987 1165">5. Click Apply. 	See A in Figure 2.

To	Do This	Notes
Create an MMS forward proxy service.	<ol style="list-style-type: none"> 1. In the browser-based tool, click Cache > Streaming. 2. Click Insert. 3. Enter the name of the service. 4. Select Forward as the Type. 5. Select MMS as the protocol. 6. In the Streaming Service dialog, enter an alternate port, if applicable. 7. Check the IP address of the forward service. 8. Set log options if you are logging the services. 9. If you are filling content through another proxy server, click Upstream Proxy Configuration. <p>For more information, see Streaming Tab in the Volera Excelerator 2.1 Administration Guide.</p>	<p>See A in Figure 2.</p> <p>IMPORTANT: If you are using the default MMS port numbers, you can only configure one MMS service per IP address.</p>

To	Do This	Notes
Configure forward proxy services for Windows Media Player 7.0 or later using MMS services.	<p>Player setup procedures vary slightly depending on the version of Windows Media Player you are using. For example, in version 7, you do the following:</p> <ol style="list-style-type: none"> 1. In the player, click Tools > Options > Network. 2. Select the protocols you want to use. 3. If necessary, configure forward proxy for MMS. 4. Check Use the Following Proxy server. 5. In the Address field, type the IP address or DNS name of the appliance's forward proxy service. 6. In the Port field, type 1755. 7. Click OK > OK. 	<p>See <i>B</i> in Figure 2.</p> <p>Use the appliance's checked IP address as the address for the forward proxy server.</p> <p>IMPORTANT: Automatic detection of proxy settings is not supported for native MMS proxy services running on port 1755.</p>

To	Do This	Notes
Configure forward proxy services for your Windows Media Player using HTTP.	<p>Player setup procedures vary slightly depending on the version of Windows Media Player you are using. For example, in version 7, you do the following:</p> <ol style="list-style-type: none"> 1. In the player, click Tools > Options > Network. 2. Select the protocols you wish to use. 3. If necessary, configure forward proxy for HTTP. 4. Check Use the following proxy server. 5. In the Address field, type the IP address or DNS name of the appliance's forward proxy service. 6. In the Port field, type 8080. 7. Click OK > OK. 	<p>See <i>B</i> in Figure 2.</p> <p>Use the appliance's checked IP address as the address for the forward proxy server.</p>
<p>(Alternative) Set up WPAD for Windows Media Player 7 or later.</p> <p>The version 7 Windows Media Players on your network can be set to automatically access the streaming forward proxy.</p> <p>important note: WPAD is only supported using MMS over HTTP.</p>	<ol style="list-style-type: none"> 1. Refer to the instructions in Web Proxy Auto-Discovery (WPAD) in the Volera Excelerator 2.1 Administration Guide. 2. Instead of configuring client browsers, configure the player using the following steps. 3. Open the player and click Tools > Options > Network. 4. Under Proxy Settings, click Configure > Autodetect Proxy Settings > OK > OK. 	

34 Volera Media Excelerator 1.1 for Windows Media Administration Guide

5

Accelerating Streams to all Players on a Network Without Configuring Them

Transparent streaming proxy services require that media player requests are routed to the appliance from a network router or switch. This chapter reviews the different router/switch configurations and contains setup instructions for each configuration type.

The four router/switch configurations are

- ◆ An L4 switch
- ◆ A WCCP-capable network router
- ◆ The appliance's internal routing service, acting as the default gateway for the network subnet being accelerated
- ◆ The appliance's internal routing service, acting as an inline (main) network router

Transparent/L4 Streaming Proxy

Key Functionality

With a transparent/L4 streaming proxy, an L4 switch on the same network as the client workstation intercepts media player requests from the client and sends them to the appliance. The transparent streaming proxy service processes the requests for the players.

How Transparent Streaming Proxy Works with an L4 Switch

Figure 4

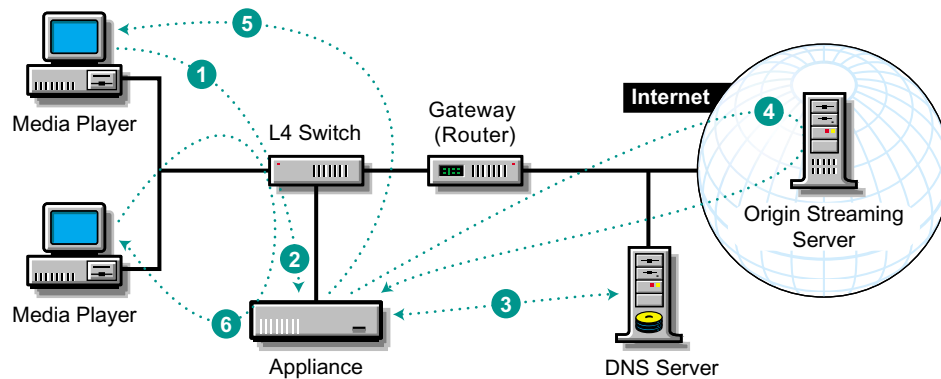

- 1 A player requests a stream from an origin streaming server.
- 2 The L4 switch detects that the request is on either port 1755 or 80, intercepts it, and sends it to the appliance's transparent streaming proxy service.
- 3 The service obtains the numeric IP address of the origin streaming server from DNS.
- 4 The service begins to fill the stream from the origin streaming server.
- 5 The service transmits the stream in real time to the player.
- 6 The transparent streaming proxy service handles subsequent requests for the same stream from cache.

Benefits of Transparent Streaming Proxy with an L4 Switch

Transparent streaming proxy doesn't require player configuration.

After the switch and the appliance are configured, proxy services are transparent to the player.

Setting Up Transparent Streaming Proxy with an L4 Switch

Figure 5 provides a visual map for the information in this section.

NOTE: The letters in Figure 5 are referenced in the table that follows. The addresses shown are for illustration purposes only. You will need to substitute actual addresses for your network.

Figure 5

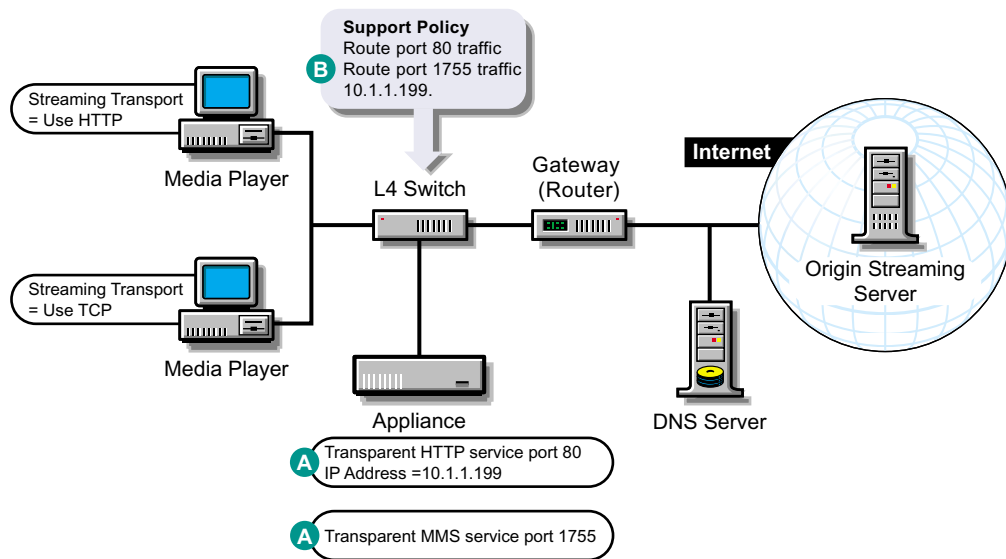

To	Do This	Notes
Understand Media Exceleator's features.	1. To ensure you achieve the results you expect, we recommend you read the information in Chapter 2, "Using Streaming with Exceleator 2.1 Features," on page 13.	
Ensure your basic network configuration is complete.	1. See Basic Network Configuration Setup in the Volera Exceleator 2.1 Administration Guide.	

To	Do This	Notes
Set up HTTP transparent proxy services on the appliance.	<ol style="list-style-type: none"> 1. In the browser-based tool, click Cache > Transparent Handling. 2. Check Enable Transparent Client Acceleration (Transparent Proxy - L4 Switch Support). 3. Ensure the Port field has 80 as its value. 4. Check the IP address for the transparent service. 5. Click Apply. 	See A in Figure 5.
Set up an MMS transparent service.	<ol style="list-style-type: none"> 1. In the browser-based tool, click Cache > Streaming. 2. Click Insert. 3. Enter the name of the service. 4. Select Transparent as the Type. 5. Select MMS as the protocol. 6. Click OK. 7. In the Streaming Service dialog box, type an alternate port, if applicable. 8. Set log options if you are logging the services. 9. If you are filling content through another proxy server, click Upstream Proxy Configuration. <p>For more information see Streaming Tab in the Volera Excelerator 2.1 Administration Guide.</p>	<p>See B in Figure 13 on page 58.</p> <p>If logging is enabled, MMS log files for the MMS accelerator server will have the same name as the MMS accelerator service. Both native MMS and HTTP-MMS requests will be logged in this log file.</p> <p>NOTE: UDP requests are filled using TCP unless the Allow UDP for Filling option is checked when a Media Cache service is created.</p>

To	Do This	Notes
Set up your L4 switch to route HTTP traffic (either port 80 or port 1755) to the appliance.	1. Follow the documentation for your switch to configure a support policy to redirect TCP port 80, TCP port 1755, and UDP port 1755 traffic to a transparent proxy address on the appliance.	See <i>B</i> in Figure 5. This will route all MMS and HTTP traffic to the appliance.

Transparent/WCCP Streaming Proxy

Key Functionality

A WCCP-capable router, which is configured as the default gateway for the client workstation, intercepts player requests from the client and routes them to the appliance. The transparent proxy service processes the request for the player.

How Transparent Streaming Proxy Works with a WCCP-Capable Router

Figure 6

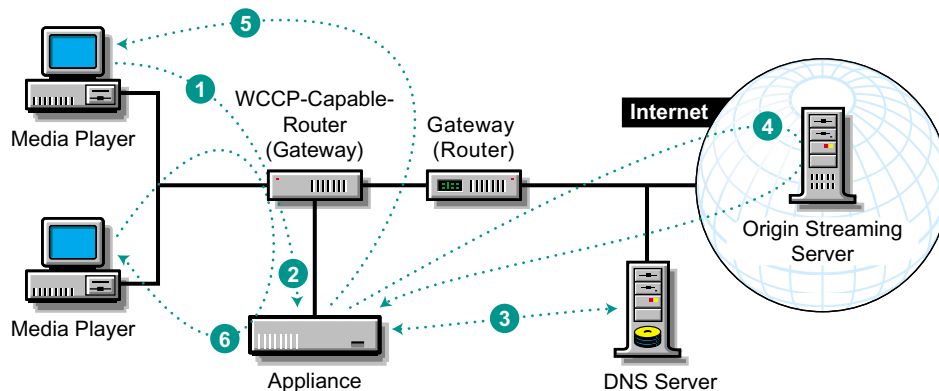

- 1 A player requests a stream from an origin streaming server.
- 2 The WCCP-capable router detects that the request is on either port 80 or port 1755, intercepts it, and sends it to the appliance's transparent streaming proxy service.
- 3 The service obtains the numeric IP address of the origin streaming server from DNS.
- 4 The service begins to fill the stream from the origin streaming server.
- 5 The service transmits the stream in real time to the player.
- 6 The transparent streaming proxy service handles subsequent requests for the same stream from cache.

Benefits of Transparent Streaming Proxy with a WCCP-Capable Router

Transparent streaming proxy doesn't require player configuration. Once the router and the appliance are configured, proxy services are transparent to the player.

Setting Up Transparent Streaming Proxy with a WCCP-Capable Router

Figure 7 provides a visual map for the information in this section.

NOTE: The letters in Figure 7 are referenced in the table that follows. The addresses shown are for illustration purposes only. You will need to substitute actual addresses for your network.

Figure 7

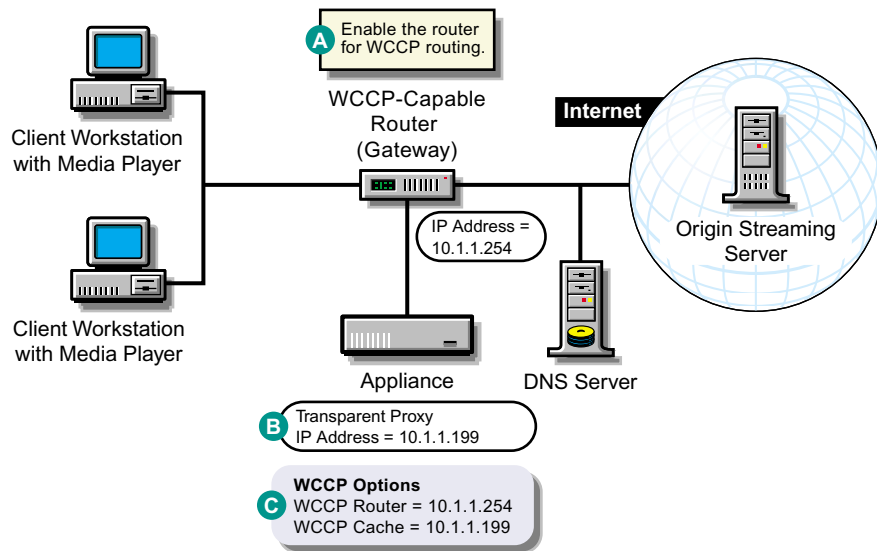

To	Do This	Notes
Understand Media Excelerator's features.	1. To ensure you achieve the results you expect, we recommend you read the information in Chapter 2, "Using Streaming with Excelerator 2.1 Features," on page 13.	
Ensure your basic network configuration is complete.	1. See Basic Network Configuration Setup in the Volera Excelerator 2.1 Administration Guide.	
Enable WCCP routing on the router.	1. By following the router manufacturer's directions, enable the router for WCCP routing.	See A in Figure 7. A WCCP-capable router can service more than one transparent proxy server.
Set up HTTP transparent proxy services on the appliance	<ol style="list-style-type: none"> 1. In the browser-based tool, click Cache > Transparent Handling. 2. Check Enable Transparent Client Acceleration (Transparent Proxy - L4 Switch Support). 3. Ensure the Port field has 80 as its value. 4. Check the IP address for the transparent service. 5. Click Apply. 	See A in Figure 7.

To	Do This	Notes
Set up an MMS transparent service.	<ol style="list-style-type: none"> 1. In the browser-based tool, click Cache > Streaming. 2. Click Insert. 3. Enter the name of the service. 4. Select Transparent as the Type. 5. Select MMS as the protocol. 6. Click OK. 7. In the Streaming Service dialog, type an alternate port, if applicable. 8. Set log options if you are logging the services. 9. If you are filling content through another proxy server, click Upstream Proxy Configuration. 	<p>See <i>B</i> in Figure 13 on page 58.</p> <p>If logging is enabled, MMS log files for the MMS accelerator server will have the same name as the MMS accelerator service. Both native MMS and HTTP-MMS requests will be logged in this log file.</p> <p>NOTE: UDP requests are filled using TCP unless the Allow UDP for Filling option is checked when a Media Cache service is created.</p>
	<p>For more information see Streaming Tab in the Volera Excelerator 2.1 Administration Guide.</p>	

To	Do This	Notes
If the routers on your network use WCCP version 1, register the appliance with a WCCP version 1 router.	<ol style="list-style-type: none"> 1. After you have enabled transparent proxy services, check Enable WCCP. 2. Click WCCP Version 1 Options. 3. Enter a proxy name and a farm name in their respective fields. (See Notes for more information.) 4. In the WCCP Router field, enter the IP address of the WCCP router. 5. In the WCCP Cache field, enter an appliance IP address configured for transparent proxy service. 6. Click Apply. 	<p>See C in Figure 7.</p> <p>The Proxy Name and Farm Name fields on the WCCP options form are text strings for your reference. They have no other function.</p> <p>The appliance needs the WCCP Router IP address in order to register with the router.</p> <p>The router needs the WCCP Cache IP address to know where to send player requests.</p> <p>An appliance can register with only one WCCP-capable router.</p> <p>If WCCP routing isn't working, try entering the <code>get stats wccp</code> command on the command line. Check the configuration for problems.</p> <p>For more information, see WCCP Version 1.0 Options Dialog Box in the Volera Excelerator 2.1 Administration Guide.</p>

To	Do This	Notes
If the routers on your network use WCCP version 2, register the appliance with the WCCP version 2 routers.	<ol style="list-style-type: none"> 1. After you have enabled transparent proxy services, check Enable WCCP. 2. Click WCCP Version 2 Options. 3. From the Cache IP Address drop-down list, select an appliance IP address configured for transparent proxy service. This IP address should also be the main appliance connection to the Internet or network containing the origin Web servers. 4. Check either Use Unicast or Use Multicast. 5. If you checked Use Multicast, enter the multicast IP address. Then click OK > Apply. Excelerator validates the address. 6. If you checked Use Unicast, insert one or more WCCP version 2 router IP addresses. 7. If you want the appliance to use signed packets for WCCP version 2 communications, check Enable Secure WCCP Communications. Then type a password and click OK. 8. Click Apply. 	<p>See C in Figure 7.</p> <p>The router needs the WCCP Cache IP address to know where to send player requests.</p> <p>Excelerator needs one or more WCCP router IP addresses in order to register with the routers.</p> <p>An appliance can register with multiple WCCP version 2 routers.</p> <p>If WCCP routing isn't working, try entering the <code>get stats wccp</code> command on the command line. Check the configuration for problems.</p> <p>For more information, see WCCP Version 2.0 Options Dialog Box in the Volera Excelerator 2.1 Administration Guide.</p>

Transparent/Default Gateway Setup

Key Functionality

With a transparent/default gateway setup, an appliance's IP address is specified as the default gateway for the client workstation that the browser resides on. The appliance provides both routing and transparent proxy services.

How Transparent Streaming Proxy Works as a Default Gateway

Figure 8

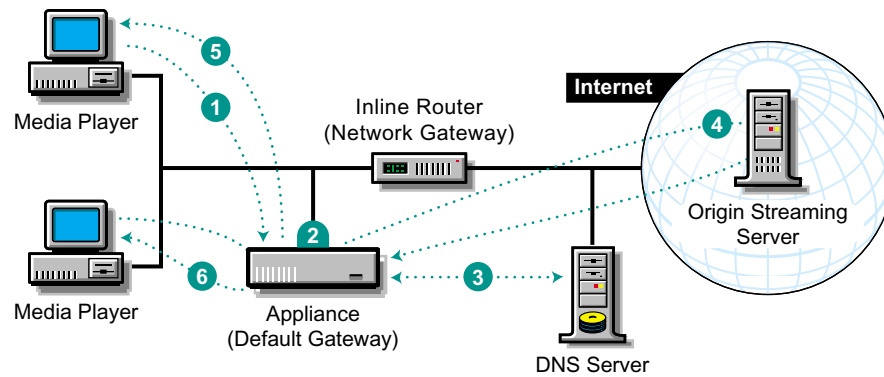

- 1 A player requests a stream from an origin streaming server.
- 2 The appliance detects that the request is to either port 80 or port 1755 and routes it to the transparent streaming proxy service.
- 3 The service obtains the numeric IP address of the origin streaming server from DNS.
- 4 The service begins to fill the stream from the origin streaming server.
- 5 The service transmits the stream in real time to the player.
- 6 The transparent streaming proxy service handles subsequent requests for the same stream from cache.

Benefits of Transparent Streaming Proxy as a Default Gateway

- ◆ Transparent streaming proxy doesn't require player configuration.
- ◆ This configuration might be useful for small business networks where the transparent proxy server is on the same subnet as the players.
- ◆ Using the appliance as a low-cost router might be sufficient for some small businesses.

Setting Up a Transparent Streaming Proxy as the Default Gateway

Figure 9 provides a visual map for the information in this section.

NOTE: The letters in Figure 9 are referenced in the table that follows. The addresses shown are for illustration purposes only. You will need to substitute actual addresses for your network.

Figure 9

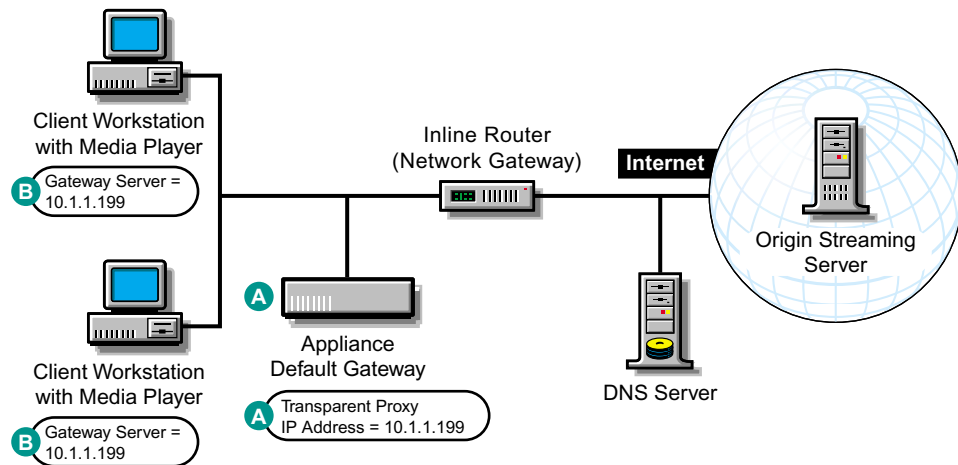

To	Do This	Notes
Understand Media Excelerator's features.	<ol style="list-style-type: none"> 1. To ensure you achieve the results you expect, we recommend you read the information in Chapter 2, "Using Streaming with Excelerator 2.1 Features," on page 13. 	
Ensure your basic network configuration is complete.	<ol style="list-style-type: none"> 1. See Basic Network Configuration Setup in the Volera Excelerator 2.1 Administration Guide. 	
Set up HTTP transparent proxy services on the appliance.	<ol style="list-style-type: none"> 1. In the browser-based tool, click Cache > Transparent Handling. 2. Check Enable Transparent Client Acceleration (Transparent Proxy - L4 Switch Support). 3. Ensure the Port field has 80 as its value. 4. Check the IP address for the transparent service 5. Click Apply. 	See A in Figure 9.

To	Do This	Notes
Set up an MMS transparent service.	<ol style="list-style-type: none"> 1. In the browser-based tool, click Cache > Streaming. 2. Click Insert. 3. Enter the name of the service. 4. Select Transparent as the Type. 5. Select MMS as the protocol. 6. Click OK. 7. In the Streaming Service dialog, type an alternate port, if applicable. 8. Set log options if you are logging the services. 9. If you are filling content through another proxy server, click Upstream Proxy Configuration. <p>For more information see Streaming Tab in the Volera Excelerator 2.1 Administration Guide</p>	<p>See <i>B</i> in Figure 13 on page 58.</p> <p>If logging is enabled, MMS log files for the MMS accelerator server will have the same name as the MMS accelerator service. Both native MMS and HTTP-MMS requests will be logged in this log file.</p> <p>IMPORTANT: If you are using the default MMS port numbers, you can only configure one MMS service per IP address.</p> <p>NOTE: UDP requests are filled using TCP unless the Allow UDP for Filling option is checked when a Media Cache service is created.</p>
Set up the appliance as a router	<ol style="list-style-type: none"> 1. After you have enabled Excelerator for transparent proxy services, check Router Options. 2. Click Router Options. 3. Set up appliance routing. 4. Click Apply. 	<p>See <i>A</i> in Figure 9.</p> <p>For more information, see Router Capabilities and Router Options Dialog Box in the Volera Excelerator 2.1 Administration Guide.</p>
Configure the client workstations to use the appliance as their gateway.	<p>Refer to setup instructions for the system.</p> <p>The procedure is different for each platform.</p>	<p>See <i>B</i> in Figure 9.</p> <p>Use the transparent proxy IP address as the gateway IP address.</p>

Transparent/Inline Router Setup

Key Functionality

With a transparent/inline router setup, an appliance's eth0 IP address is specified as the default gateway for the client workstations that the players reside on. The eth1 port connects to the Internet. The appliance provides routing and caching services and serves as the gateway to the Internet.

How Transparent Streaming Proxy Works as an Inline Router

Figure 10

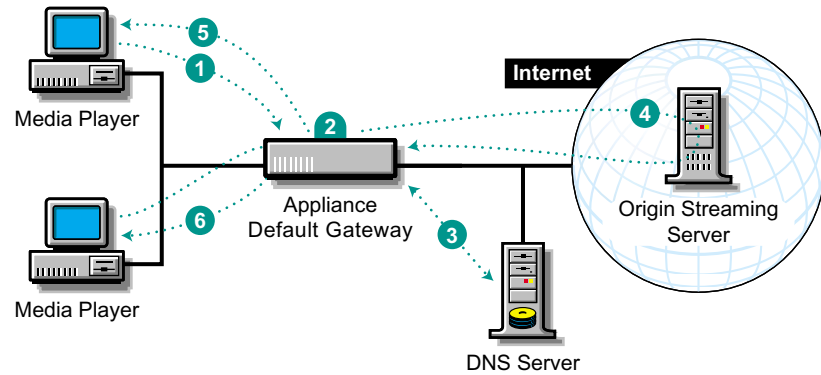

- 1 A player requests a stream from an origin streaming server.
- 2 The appliance detects that the request is on either port 80 or port 1755, and routes it to the transparent streaming proxy service.
- 3 The service obtains the numeric IP address of the origin streaming server from DNS.
- 4 The service begins to fill the stream from the origin streaming server.
- 5 The service transmits the stream in real time to the player.
- 6 The transparent streaming proxy service handles subsequent requests for the same stream from cache.

Benefits of Transparent Streaming Proxy as an Inline Router

- ◆ Transparent streaming proxy doesn't require player configuration.
- ◆ This configuration might be useful for small business networks where all the client workstations and the transparent proxy server are on the same network.
- ◆ Using the appliance as a low-cost router might be sufficient for some small businesses.

Setting Up a Transparent Streaming Proxy as an Inline Router

Figure 11 provides a visual map for the information in this section.

NOTE: The letters in Figure 11 are referenced in the table that follows. The addresses shown are for illustration purposes only. You will need to substitute actual addresses for your network.

Figure 11

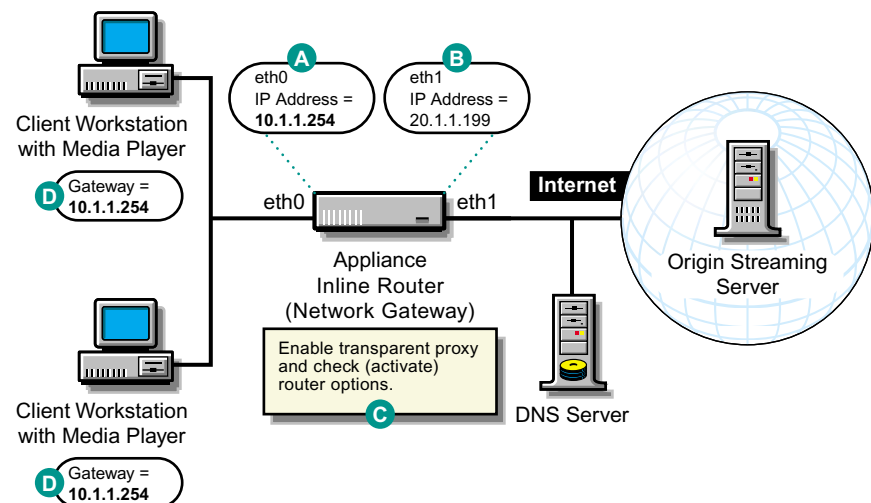

To	Do This	Notes
Understand Media Excelerator's features.	<ol style="list-style-type: none"> 1. To ensure you achieve the results you expect, we recommend you read the information in Chapter 2, "Using Streaming with Excelerator 2.1 Features," on page 13. 	
Ensure your basic network configuration is complete.	<ol style="list-style-type: none"> 1. See Basic Network Configuration Setup in the Volera Excelerator 2.1 Administration Guide. 	
Configure the network adapters for inline routing.	<ol style="list-style-type: none"> 1. In the browser-based tool, click Network > IP Addresses. 2. Configure eth0 with an IP address on the same subnet as the client workstations. 3. Configure eth1 with an IP address on the network. 4. Click Apply. 	<p>See A in Figure 11 on page 51.</p> <p>The eth0 IP address handles transparent proxy services and doubles as the gateway address for all client workstations on the subnet.</p> <p>See B in Figure 11 on page 51.</p> <p>The eth1 IP address provides access to the network.</p>
Set up HTTP transparent proxy services on the appliance.	<ol style="list-style-type: none"> 1. In the browser-based tool, click Cache > Transparent Handling. 2. Check Enable Transparent Client Acceleration (Transparent Proxy - L4 Switch Support). 3. Ensure the Port field has 80 as its value. 4. Check the IP address for the transparent service. 5. Click Apply. 	<p>See A in Figure 11 on page 51.</p>

To	Do This	Notes
Set up an MMS transparent service.	<ol style="list-style-type: none"> 1. In the browser-based tool, click Cache > Streaming. 2. Click Insert. 3. Enter the name of the service. 4. Select Transparent as the Type. 5. Select MMS as the protocol. 6. Click OK. 7. In the Streaming Service dialog, type an alternate port, if applicable. 8. Set log options if you are logging the services. 9. If you are filling content through another proxy server, click Upstream Proxy Configuration. <p>For more information see Streaming Tab in the Volera Excelerator 2.1 Administration Guide</p>	<p>See <i>B</i> in Figure 13 on page 58.</p> <p>If logging is enabled, MMS log files for the MMS accelerator server will have the same name as the MMS accelerator service. Both native MMS and HTTP-MMS requests will be logged in this log file.</p> <p>NOTE: UDP requests are filled using TCP unless the Allow UDP for Filling option is checked when a Media Cache service is created.</p>
Set up the appliance as a router.	<ol style="list-style-type: none"> 1. After you have enabled Excelerator for transparent proxy services, check Router Options. 2. Click Router Options. 3. Set up appliance routing. 4. Click Apply. 	<p>See <i>C</i> in Figure 11 on page 51.</p> <p>For more information, see Router Capabilities and Router Options Dialog Box in the Volera Excelerator 2.1 Administration Guide.</p>
Configure the client workstations to use the appliance as their gateway.	Refer to setup instructions for the system.	<p>See <i>D</i> in Figure 11 on page 51.</p> <p>Use the transparent proxy IP address as the gateway IP address.</p>

54 Volera Media Excelerator 1.1 for Windows Media Administration Guide

6 Accelerating Streaming Media Servers

This section focuses on the benefits and setup for accelerating streaming media servers. The streaming media accelerator appliance relies on DNS in order for the accelerator to receive requests originally targeted at the origin streaming server. The streaming media accelerator appliance handles the requests, accessing the origin streaming server only when required objects are not cached and for handling some control messages.

How Origin Streaming Server Acceleration Works

The mechanism for routing player requests to the streaming media accelerator instead of to the origin streaming servers can be summarized as follows:

- ◆ Without acceleration, DNS resolves the origin streaming server's DNS name to the origin streaming server's IP address.
- ◆ With acceleration, DNS resolves the server's name to the IP address of an appliance streaming media accelerator (reverse proxy) service.

Figure 12

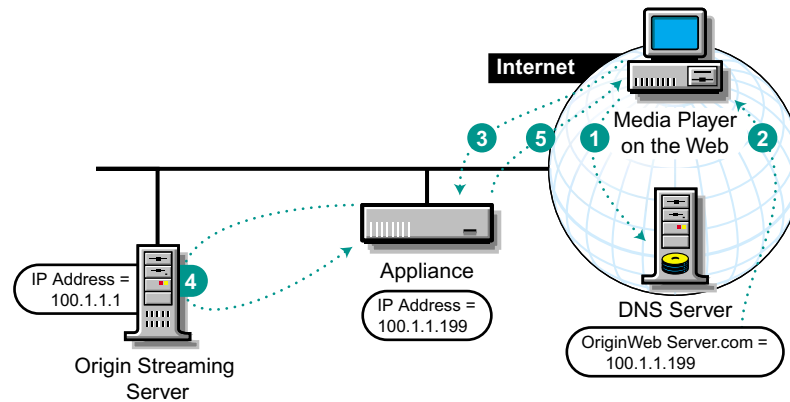

- 1 A player requests a stream from an origin streaming server. This generates a request to DNS for the numeric IP address of the origin streaming server.
- 2 Instead of returning the origin streaming server's numeric IP address, DNS returns the numeric IP address of the accelerator service on the appliance.
- 3 The player requests the stream using the numeric IP address of the accelerator service.
- 4 The accelerator service begins filling the stream from the origin streaming server.
- 5 The accelerator service transmits the stream in real time to the player.

Benefits of Origin Streaming Server Acceleration

- ◆ A streaming server accelerator reduces response time to media player requests and frees up origin streaming server bandwidth, allowing it to handle requests for less frequently requested, uncached streams much more quickly.
- ◆ The appliance can accelerate origin streaming servers at remote locations that don't offer high bandwidth connections. The streaming server accelerator can be located close to the Internet backbone, delivering high-speed access to browsers for all cached objects.
- ◆ An accelerator scales the number of players that can be serviced with a single server.

For tips and guidelines on setting up origin streaming server accelerators, see "Streaming Server Accelerator Setup" on page 58.

The procedure for configuring DNS to work with Web server accelerators is explained in *Working with DNS in the Volera Exceleator 2.1 Administration Guide*.

Streaming Server Accelerator Setup

Figure 13 provides a visual map for the information in this section.

NOTE: The letters in Figure 13 are referenced in the table that follows. The addresses shown are for illustration purposes only. You will need to substitute actual addresses for your network.

Figure 13

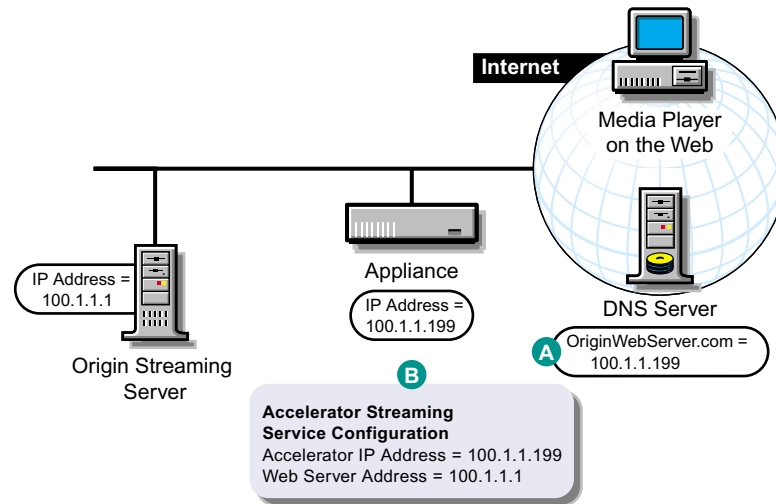

To	Do This	Notes
Understand Media Excelerator's features.	1. To ensure you achieve the results you expect, we recommend you read the information in Chapter 2, "Using Streaming with Excelerator 2.1 Features," on page 13.	
Ensure your basic network configuration is complete.	1. See Basic Network Configuration Setup in the Volera Excelerator 2.1 Administration Guide.	

To	Do This	Notes
Ensure that DNS resolves browser requests to the appliance IP addresses configured for the streaming server accelerator services.	1. See Working with DNS in the Volera Excelerator 2.1 Administration Guide.	See A in Figure 13 on page 58.
Increase the number of concurrent connections that can be serviced by the Windows Media server.	<ol style="list-style-type: none"> 1. If the Windows media server is running both IIS and MMS, ensure that the MMS service has HTTP enabled. 2. Ensure that the services use different IP addresses. 	<p>If you know that users will never connect via HTTP, then it is not necessary to enable HTTP support on your Windows Media Server. You will not need to set up an HTTP accelerator service, as mentioned on the following page. This would be a rare circumstance.</p> <p>If the server is running both IIS and MMS, you will need to create two Web accelerators on the appliance—one to accelerate the server IP address handling IIS traffic and another to accelerate the server IP address handling MMS traffic.</p>

To	Do This	Notes
Set up an HTTP accelerator service	<ol style="list-style-type: none"> 1. In the browser-based tool, click Cache > Web Server Accelerator > Insert. 2. Check Enable. 3. Enter a name for the streaming server accelerator for your tracking purposes. 4. Enter a DNS name, if desired. 5. Enable logging and set up logging options, if desired. 6. Ensure the Web Server and Accelerator Port field values are both 80. 7. In the Accelerator IP Address list, check one or more addresses that the Web server accelerator will receive requests and vend data on. (DNS resolves requests to these addresses.) 8. In the Web Server Addresses list, insert the server IP addresses (or DNS names) of the servers being accelerated. 9. Click OK. 10. Click Apply. 	<p>See <i>B</i> in Figure 13 on page 58.</p> <p>If logging is enabled, accelerator log files for the Web server accelerator will have the same name as the Web server accelerator.</p> <p>IMPORTANT: If you are using the default HTTP port numbers, you can only configure one HTTP service per IP address.</p> <p>If you enter DNS names in the Web Server Addresses list, make sure they are not the names that now resolve to the appliance's numeric IP addresses. That would create an endless loop.</p>

To	Do This	Notes
Set up an MMS accelerator service.	<ol style="list-style-type: none"> 1. In the browser-based tool, click Cache > Streaming. 2. Click Insert. 3. Enter the name of the service. 4. Select Accelerator as the Type. 5. Select MMS as the protocol. 6. Click OK. 7. In the Streaming Service Dialog box, type an alternate port, if applicable. 8. In the Accelerator IP Address list, select one or more addresses that the Web server accelerator will receive requests and vend data on. (DNS resolves requests to these addresses.) 9. Set log options if you are logging the services. 10. In the Web Server Addresses list, insert the server IP addresses (or DNS names) of the servers being accelerated. 	<p>See <i>B</i> in Figure 13 on page 58.</p> <p>If logging is enabled, MMS log files for the MMS accelerator server will have the same name as the MMS accelerator service. Both native MMS and HTTP-MMS requests will be logged in this log file.</p> <p>IMPORTANT: If you are using the default MMS port numbers, you can only configure one MMS service per IP address.</p> <p>If you enter DNS names in the Web Server Addresses list, make sure they are not the names that now resolve to the appliance's numeric IP addresses. That would create an endless loop.</p> <p>NOTE: UDP requests are filled using TCP unless the Allow UDP for Filling option is checked when a Streaming service is created.</p>
	<p>For more information, see Streaming Tab in the Volera Exceleator 2.1 Administration Guide.</p>	

62 Volera Media Excelerator 1.1 for Windows Media Administration Guide

7

Streaming Content Through Firewalls

This section discusses the process of getting streaming content through firewalls. Most firewalls block MMS-TCP/UDP traffic, as shown in Figure 14.

Figure 14 MMS-TCP/UDP Traffic Is Blocked by Most Firewalls

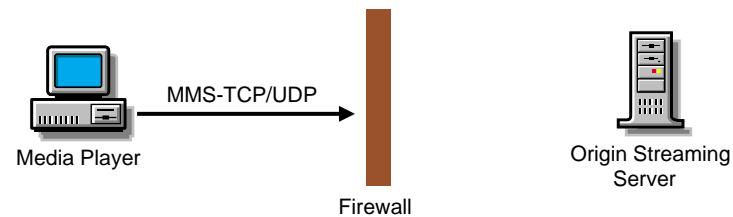

MMS-HTTP requests, on the other hand, pass through most firewalls, as shown in Figure 15.

Figure 15 MMS Traffic Passes Through Most Firewalls

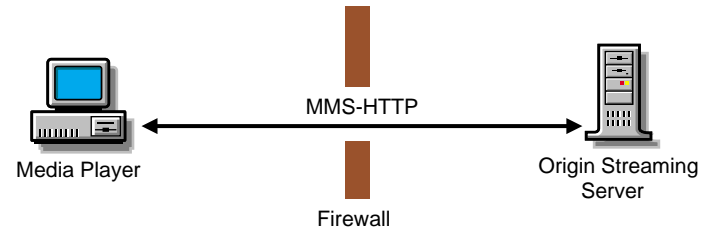

Figure 15 illustrates why MMS in HTTP is widely used for MMS streaming on the Web. The MMS-HTTP packets pass through most firewalls, and the

MMS data embedded in the packets lets the Windows Media players communicate with the streaming servers.

Setting Up Your Appliance to Work with NATs and Firewalls

Most firewalls and NATs will not support the MMS-UDP protocol, which uses dynamically allocated UDP ports. Your firewall may or may not support the MMS-TCP protocol, which uses TCP port 1755. Most firewalls will support the MMS-HTTP format, which uses the standard HTTP port 80.

There are two common configurations which may be used in a firewall or NAT situation.

Placing the Appliance Outside the Firewall

In this configuration, the firewall is used to force all players to use the MMS-HTTP protocol. If a player is configured to use TCP/UDP, it will make an initial attempt to connect to TCP port 1755. This will be blocked by the firewall, causing it to connect to the appliance using the MMS-HTTP protocol, as shown in Figure 16.

Figure 16

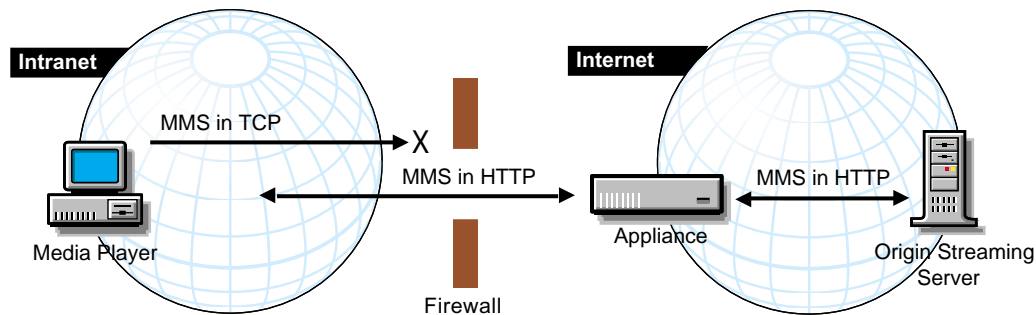

In this scenario, all appliance IP addresses, the default gateway, and the DNS server are on subnets outside the firewall.

NOTE: This approach does not apply to players configured to only use the UDP/TCP transport option.

Placing the Appliance Inside the Firewall

In this configuration, players can connect to the appliance using any of the MMS protocol options (HTTP, TCP, UDP). The firewall must be able to pass both MMS-HTTP and MMS-TCP packets. Because MMS-UDP packets cannot pass through the firewall, the appliance must be configured to only use TCP for filling. This is done by ensuring that the Allow UDP Upstream option is not checked when configuring the MMS service. This option is not checked by default.

If a player connects to the appliance using MMS-HTTP, the appliance will use MMS-HTTP to communicate with the origin server. If a player connects to the appliance using MMS-TCP or MMS-UDP, the appliance will use MMD-TCP to communicate with the origin server. This is illustrated in Figure 17.

Figure 17

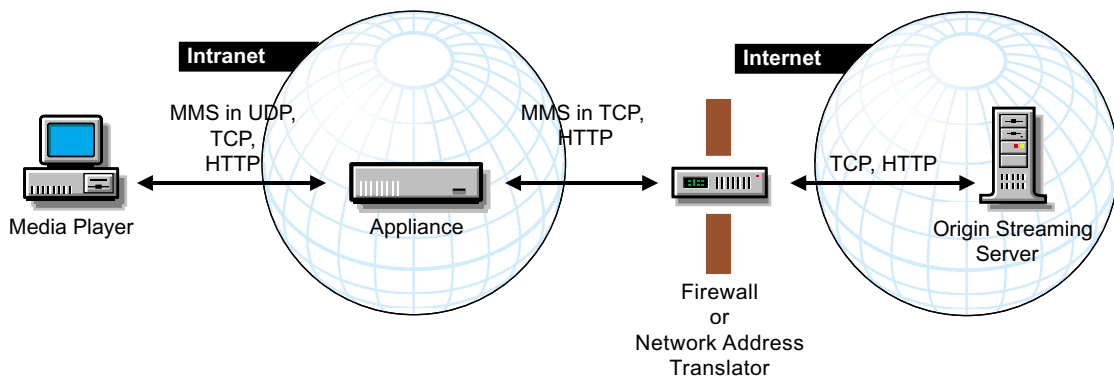

In these scenarios, the appliance IP addresses, the default gateway, the DNS server, and the proxy service on the firewall or network address translator would all be on subnets inside the firewall.

Using the Appliance as a Component to the Firewall

If neither of the previous two options is possible for your network, you can configure the appliance as a firewall component by doing the following:

- ◆ Using IP addresses on network cards that are on subnets inside the firewall to receive forward and/or transparent streaming requests
- ◆ Using IP addresses on other network cards that are outside the firewall to communicate with origin streaming servers on the Web

Figure 18 illustrates this scenario.

Figure 18

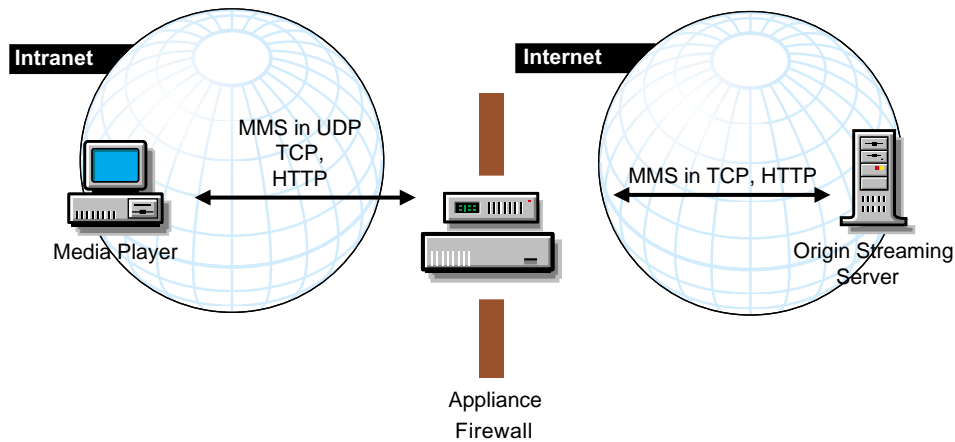

In this scenario, the appliance has two adapters: one adapter inside the firewall and one outside. An advantage of this is that the firewall does not interfere with the appliance. The appliance IP addresses would be both inside and outside the firewall, depending on the network cards to which they were assigned. The default gateway and the DNS server would be on subnets outside the firewall.

For more information on protocols, see Chapter 1, “Overview of Windows Media Player Protocols,” on page 9.

Index

A

- acceleration
 - benefits of origin streaming server 57
 - setting up origin streaming server 58
- accelerator service, HTTP
 - setting up 60
- accelerator service, MMS
 - setting up 61
- access
 - providing multiple-player, to MMS and QuickTime streams 14
- activation license
 - installing, from floppy disk 24
 - installing, using FTP 24
- appliance
 - setting up, to work with firewalls 64
- appliance caching activity, logging 16
- appliances
 - and streaming media accelerator 55
 - backup system image 26
 - enabling HTTP forward proxy services on 30
 - installing Media Excelerator patches on 25
 - logging caching activity 16
 - registering WCCP router with 44, 45
 - setting up client workstations to use, as gateways 53
 - setting up L4 switch to route HTTP traffic to 39
 - setting up, as routers 49, 53
 - updating clone images 26
 - using, as components in firewalls 65
 - using, as gateways 49
- authentication
 - streaming services 15

B

- backup system image, updating 26

C

- cache
 - managing freshness 14
 - preloading streams into 13
 - purging objects from 16
- cache freshness revalidation settings 14
- caching activity, logging appliance 16
- client workstations
 - configuring, to use appliances as gateways 53
- clone image, appliance 26

D

- DNS
 - and appliances 55
 - and origin streaming server acceleration 56
 - resolve browser requests to appliance IP addresses 59
 - resolving browser requests to appliance IP addresses 59

E

- eth0 IP address, default gateway for client workstations 50
- eth1 port, connection to Internet 50
- Excelerator 2.1
 - live stream splitting feature 14
 - preloading streams into cache 13
 - site download feature 13
 - support for MMS live streams 14
- extended log field headers 19, 20

F

- field headers, extended log 19, 20
- field values in extended log files 19, 20
- filenames
 - using browser-based management tool to get log 17

- using command line to get log 18
 - using FTP to get log 18
 - using Telnet to get log 18
 - filenames, log 17
 - files, log
 - deleting 16
 - downloading 16
 - firewalls
 - allowing MMS-HTTP traffic through 63
 - blocking MMS-UDP traffic with 63
 - setting up appliances, to work with 64
 - using appliances as components in 65
 - forward proxy services
 - creating MMS 31
 - creating, for Windows Media Player 32
 - enabling HTTP, on appliances 30
 - forward streaming proxy 27
 - benefits of 28
 - function of 27
 - how it works 28
 - setup 29
 - forward streaming proxy services
 - setting up 30
 - FTP
 - downloading log files with 19
 - using, to install activation license 24
 - FTP Log Push feature 16
- G**
- gateway, setting up transparent streaming proxy as
 - default 47
 - gateway, using transparent streaming proxy as
 - default 46
 - gateways
 - configuring client workstations to use
 - appliances as 49
 - setting up workstations to use appliances as 53
- H**
- headers, extended log field 19, 20
 - HTTP
 - enabling, forward proxy services on appliances
 - 30
 - setting up, accelerator service 60
 - setting up, transparent proxy services on
 - appliances 38, 42, 48, 52
 - HTTP accelerator service
 - setting up 60
 - HTTP traffic, setting up L4 switch to route 39
 - HTTP transparent proxy services
 - setting up, on appliances 38, 42, 48, 52
- I**
- inline router
 - and transparent streaming proxy 50
 - benefits of using transparent streaming proxy as
 - 51
 - setting up transparent streaming proxy as 51
 - inline routing
 - setting up network adapters for 52
 - IP address
 - forward streaming proxy services 27
 - IP address, proxy service 65
 - IP appliance addresses
 - using DNS to resolve browser requests to 59
- L**
- L4 switch
 - and transparent streaming proxy services 36
 - benefits of using, with transparent streaming
 - proxy services 36
 - setting up transparent streaming proxy services
 - with 37
 - setting up, to route HTTP traffic to appliance 39
 - license
 - backing up 26
 - purchasing Media Excelerator 23
 - license, activation 24
 - live stream splitting feature, Excelerator 2.1 14
 - log field headers, extended 19, 20
 - log filenames, listing 17
 - log files
 - deleting 16
 - deleting downloaded 19
 - determining path to 17
 - downloading 16
 - downloading, with browser-based management
 - tool 19
 - downloading, with FTP 19
 - field values in 19, 20
 - listing names of 17
 - naming conventions 17
 - rollover options 17
 - using FTP Log Push feature 16

logging appliance caching activity 16

M

management tool, browser based 17, 19

Media Excelerator

backing up, license 26

installing patches 25

purchasing license 23

revalidates objects with every request 14

media file

downloading 15

media server, Windows

configuring 59

MMS

creating, forward proxy services 31

setting up transparent services 38, 43, 49, 53

setting up, accelerator service 61

MMS accelerator service

setting up 61

MMS in HTTP, and Windows Media Player 10

MMS in TCP, and Windows Media Player 10

MMS in UDP, and Windows Media Player 11

MMS live streams

providing support for 14

MMS log files, determining path to 17

MMS proxy

configuring as an upstream proxy 65

MMS streaming

and MMS-HTTP packets 63

MMS streams

caching 13

providing multiple-player access to 14

MMS transparent services, setting up 38, 43, 49, 53

MMS-HTTP packets

passing through firewalls 63

MMS-HTTP traffic, passing through firewalls 63

MMS-UDP traffic, blocking with firewalls 63

N

network adapters

setting up, for inline routing 52

network address translator

proxy service 65

O

objects

downloading streaming 15

pinning 15

purging streaming 16

origin streaming server acceleration 56

benefits of 57

setting up 58

P

patches

downloading latest product 25

installing, for Media Excelerator 25

pinning list 15

port number, proxy service 65

protocol support, Windows Media Player 10

MMS in HTTP 10

MMS in TCP 10

MMS in UDP 11

proxy services

creating forward, for Windows Media Player 32

creating MMS forward 31

function of forward streaming 27

setting up forward streaming 30

proxy services, forward streaming 27

proxy services, transparent streaming 35

and L4 switches 36

benefits of using, with L4 switches 36

functions of 36

setting up, with L4 switch 37

proxy, forward streaming 27

purging

from cache 16

Q

QuickTime streams

providing multiple-player access 14

R

rollover options, log files 17

router

benefits of using transparent streaming proxy as inline 51

setting up transparent streaming proxy as inline 51

- using transparent streaming proxy as inline 50
- router, WCCP-capable 40, 41
 - enabling routing on 42
 - setting up transparent streaming proxy with 41
- routers
 - setting up appliances as 49, 53
- routing
 - enabling WCCP, on router 42
- routing, inline
 - setting up network adapters for 52

S

- server acceleration, streaming media 55
- services
 - authenticating streaming 15
- setup
 - forward streaming proxy 29
- site download feature, Excelerator 2.1 13
- stream splitting feature, Excelerator 2.1 14
- streaming
 - caching content 13
- streaming media server acceleration, overview of 55
- streaming objects
 - downloading 15
 - pinning 15
 - purging 16
- streaming proxy, transparent 35
 - and L4 switch 36
 - benefits of using L4 switch with 36
 - functions of 36
 - setting up with L4 switch 37
- streaming requests 27
- streaming server acceleration, origin 56
 - benefits of 57
 - setting up 58
- streaming services
 - authenticating 15
- streams
 - live 14
 - preloading into cache 13
 - providing multiple-player access to 14
 - providing support for live 14
- streams, MMS
 - caching 13

T

- transparent proxy services
 - and WCCP-capable router 40
 - benefits of using, with WCCP-capable router 41
 - setting up HTTP, on appliances 38, 42, 48, 52
 - setting up, with WCCP-capable router 41
- transparent services
 - setting up MMS 38, 43, 49, 53
- transparent streaming proxy
 - benefits of using, as inline router 51
 - setting up, as default gateway 47
 - setting up, as inline router 51
 - used as inline router 50
 - using, as default gateway 46
- transparent streaming proxy services 35
 - functions of 36

V

- Volera Media Excelerator
 - for Windows Media Player 10

W

- WCCP router
 - registering appliance with 44, 45
- WCCP routing
 - enabling 42
- WCCP, registering appliance with 44, 45
- WCCP-capable router
 - and transparent proxy service 40
 - benefits of using, with transparent proxy service 41
 - setting up transparent proxy service with 41
- Windows Media objects
 - don't expire in cache 14
 - reasons, are removed 14
 - revalidated with each request 14
- Windows Media Player
 - and MMS in HTTP 10
 - and MMS in TCP 10
 - and MMS in UDP 11
 - creating, forward proxy services for 32
 - protocol support 10
 - setting up WPAD for 33
- Windows media server
 - configuring 59
- workstations, client
 - configuring, to use appliances as gateways 49
- WPAD, setting up for Windows Media Player 33

70 Volera Media Excelerator 1.1 for Windows Media Administration Guide

72 Volera Media Excelerator 1.1 for Windows Media Administration Guide